



# CHREZO

## MODÉLISME FERROVIAIRE

NEWSLETTER N°34 - June 6, 2023

## SNCF DIESEL-ELECTRIC BB 67000 SERIES

### ARE 60 YEARS OLD!



**CHREZO**  
MODÉLISME FERROVIAIRE

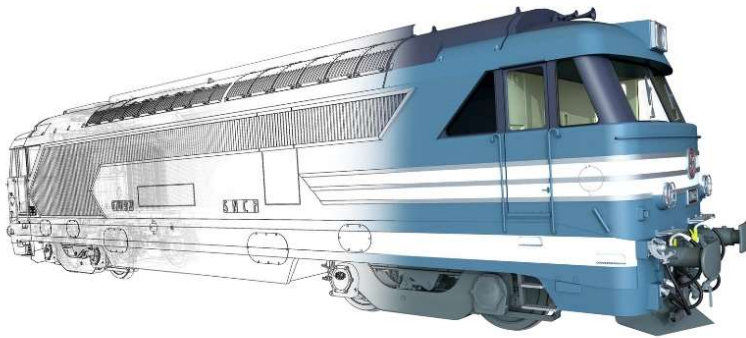

Dear Customer,

After the 140 C steam locomotive launched in 2018 and the X 3800 railcar in 2020, we are proud to announce the release of our third engine, the BB 67000 and its evolutions 67200 and 67300. This project is fully detailed in the next pages.

You will also enjoy the first X 3800 « Picasso » pictures, assembled with the injection parts, which have already been posted on our Facebook page. They immediately augur a very beautiful model!

Enjoy your reading !

### Coils transport car SNCF Shis 50.2 :

Produced in partnership with the German magazine SNM and Lenz, our model is progressing well, as evidenced by this decoration sample.

Delivery is now expected in September.

Available only in UIC lettering, era 4-5, at a price of €215.00 including tax in E.U. or €183.34 for UK and Switzerland customers.

Be careful, only 30 remaining pieces are available.



**X 3800 Picasso Railcar** : Just received on June, 1st, « Engineering sample » interesting pictures !

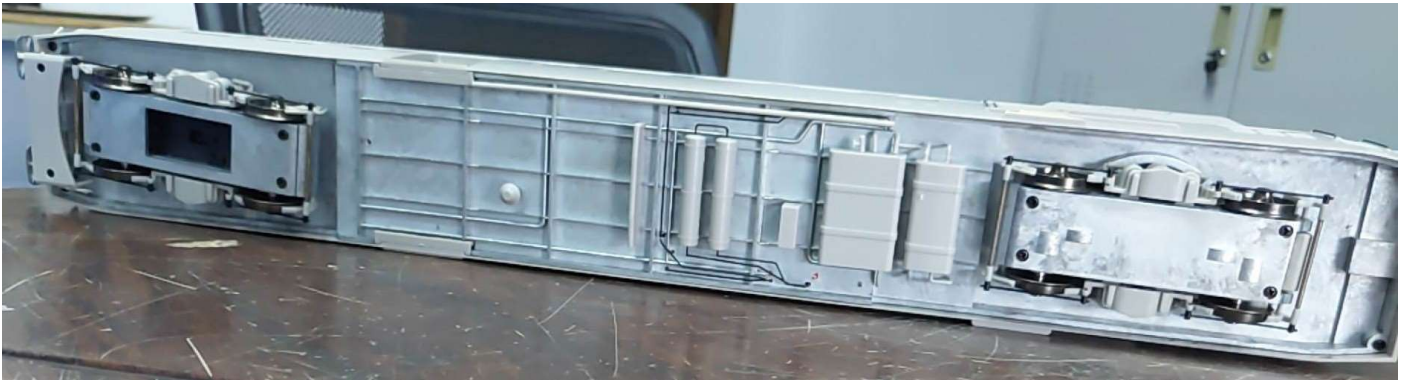

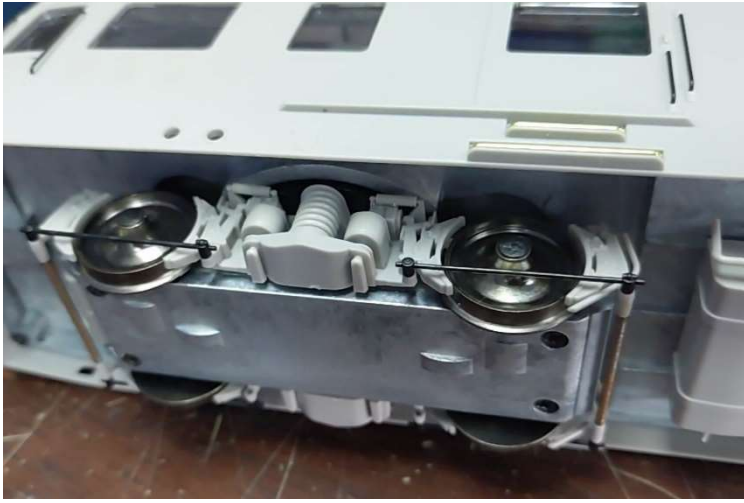

What else ? The german firm ESU is designing the electric network and the electronic PCB. So we expect to show a fonctionnal sample in Stafford in September



## CHREZO 'S NEXT PROJECT : BB 67000 DIESEL LOCOMOTIVES !



Like yours truly, these iconic machines celebrate their 60th birthday in 2023! On this occasion, it seemed opportune to offer you a zero scale reproduction with an best value. This choice obeys the same logic as our 2 previous models: strong notoriety and universal use potential of the real machine (variety of convoys, vast geographical distribution, long period of use), reference to the modeltrain which enchanted our childhood and our adolescence.



We have also decided to use again the Ulule crowdfunding platform, now well known to the general public, to launch the project. Fun, it allows everyone to see firsthand the progress of subscriptions and the collected amount, and to decide immediately at the end of the campaign on the launch or not of the model.

Please, connect you on : <https://fr.ulule.com/bb-67000-echelle-zero/> and choose the variation you are very fan about !

Payments are possible with International bank transfer or CB card. PayPal is not longer allowed on Ulule.

Considering our 140C et and X3800 models experience, we decided that **150** contributors for **699€** (inkl. VAT) are enough to start the project. Once this goal reached, we are sure to receive the funding but, of course, you can continue to contribute, which will allow us to invest more quickly in other projects.

Please note, CHREZO reserves the right not to industrialize versions that do not reach a minimum of 20 orders. Use word of mouth, mobilize your family and friends and, just in case, think of a second choice

On the other hand, if the number of 150 supporters, all versions combined, is not reached, the project will be cancelled and Ulule will fully refund all payments made. In this case, CHREZO does not receive any amount and cannot, under any circumstances, be put on notice to continue the project.

Please note that this crowdfunding campaign ends on **July 31 at midnight**. After, it will be too late...

## Common features to our 6 versions of the BB 67000 diesel locomotive :

- Very finely detailed model, using 400 parts (plastic injected and Die-cast, photo-etched parts)
- ABS plastic body, Die cast chassis
- 1/43,5 scale- Overall length : 393 mm
- 2 powered trucks with flywheeled motors
- Curve radius : 1020 mm
- White/red reversing headlights
- Cab lighting – 3rd front headlight
- Photoetched sidewalls and fan grids
- 2 functional fans
- 1,2 mm flange according to Fine Scale standards
- Sprung buffers – Screw couplers
- NEM interface for Lenz couplers
- Analogic model, with DCC ESU type "L" interface
- DCC Sound option available for delivery

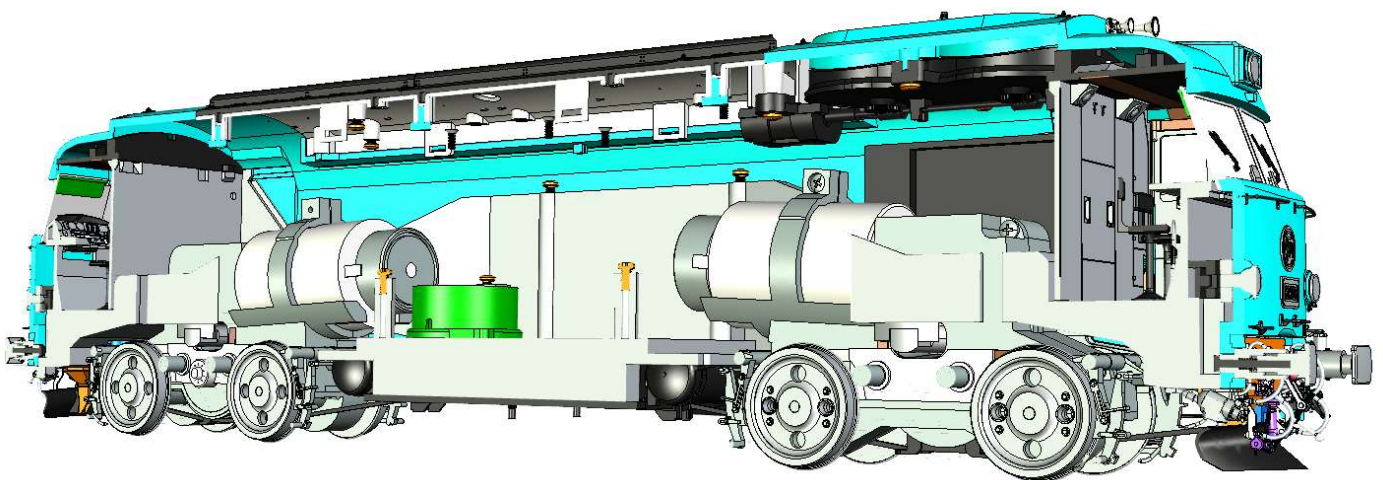
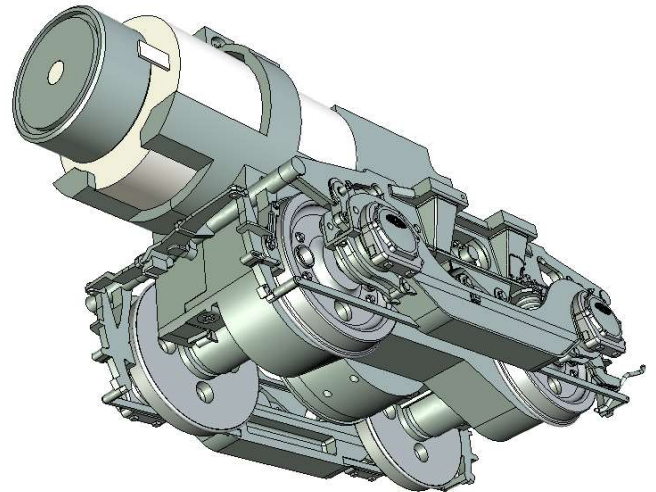

The project design is very advanced, since all the necessary 3D drawings for the machining of the tools are 99% finalized. It is a French design but, for the third time, the manufacturing will be entrusted to our partner HELIXON.

**About the price:** The subscription price is final. It is higher than that of our previous models because we only plan to produce 600 copies. Consequently, the tools will be amortized over a smaller quantity produced, which mechanically increases the manufacturing price of each piece. In return for their commitment, subscribers benefit from a decisive commercial advantage, because the sale price will increase significantly for models marketed after delivery (around 25%). A DCC Sound option (with additional charges) will be available when the model is delivered but its cost has not been determined yet.

**About production schedule :** our vendor HELIXON having returned to pre-COVID production conditions, we hope to deliver the model within a maximum of 18 to 24 months after the crowdfunding campaign closing.

**The variants offered:** For a limited production to 600 pieces, that matches to the french Scale market size, an effort to rationalize the tools proved essential so that the model remains at an attractive price. We have therefore decided to offer you locomotives from the BB 67092 to 67124 sub-series. This offer avoids duplicating the locos with panoramic corner windows and pendular suspension already offered by Lemaco, AMJL and ... Lima!

A second tool will make it possible to obtain the configuration with a reinforced cabin with its specificities: removal of the aluminum hubcaps, red lights fitting, roller axle bearings, U6 buffers, buffering beam predisposed for the AATC automatic coupling.

## BB 67000 SERIES : **CHREZO** RANGE AT A GLANCE...

### V1 : Locomotive SNCF BB 67092, genuine livery (Rennes)

**Ep. 3-4** The engine is offered in its genuine aspect, as it starts its service in 1966 in Rennes shed. In 1975, it was completely upgraded with a reinforced cabin and electric heating for the passengers coaches, then moved to Nantes shed in April with BB 67371 running number.



### V2 : Locomotive SNCF BB 67112, genuine livery (Clermont)

**Ep. 3-4** The real locomotive was put into in Mai 1967 in Clermont shed. Its following sheds in this livery were Nevers (9-69) ; Vénissieux (9-73) ; Nevers (10-79). En January of 1981, it was transformed in Nevers as TGVline maintenance engine with the running number BB 67218.



### V3 : Locomotive SNCF BB 67310, genuine livery (Chambéry)

**Ep. 3-4** Our model belongs to the BB 67301 à 67370 sub-series, and it was put into service during Mars 1968 in Chambéry shed. In this livery, its following sheds were Vénissieux (12-69) and Tours SP (until 9-75)



### V4 : Locomotive SNCF BB 67337, genuine livery (Strasbourg)

**Ep. 3-4** Our model belongs to the BB 67301 à 67370 sub-series, and was put into service during January 1969 in Strasbourg shed. In this livery, its following sheds were Tours-SP (10-72) and Bordeaux (until 9-75).



### V5 : Locomotive SNCF BB 67375, cabine renforcée (Caen)

**Ep. 4-5** Born with running number BB 67116, the engine was completely upgraded in 1975 with a reinforced cabin, fitted red endlights and a powerful generator that allows passenger-trains electric heating.

Newly registered as BB 67375 it was put into service in Caen again in November 1976, then in Rennes and Tours (8-99).



### V6 : Locomotive SNCF 667210, INFRA livery (Longueau)

**Ep. 5-6** Born as BB 67120 in October 1967, this engine was dedicated to TGV line support and moved as BB 67210 to Nevers during June 1981. Later, it moves to La Villette shed (5-94) then Longueau shed (1-96). During 2003, it received this very spectacular INFRA livery, that makes it unique ! Accordingly to its prototype, the model will receive upper fitted wipers.



### V7 : Support to BB 67000 project with delayed choice

If you want to bring your tribute to this adventure but choose your model later, please select the V7 variation on Ulule.

## 2022 NEW RELEASES :

At this step, we don't have any information about 2023 new releases.

### **SCHNELLENKAMP : bogie tank cars SNCF - SPCC – July 2023**



1/45

Subscribers are invited to pay their invoice before the delivery, expected for the middle of July.

All the 75 models are booked – No remaining stock

### **LENZ : UIC SNCF vans Gs4-01 – September 2023**



42245-04 : SNCF K 340 689



42245-05 : SNCF K 343 274



42245-06 : SNCF 87 121 3153-3

1/45

### **DAPOL: 66036 EURO CARGO RAIL**



1/43,5

Still waiting for more informations from DAPOL about the upgraded tools and production schedule...

**EXHIBITIONS :** We confirm that we will stay in the following shows :

- Guildex in Stafford (UK) 2 et 3 September 2023, in partnership with Minerva Model Railways
- Laval, 30 September et 1st October 2023
- Savoie-Modélisme in Chambéry, 28 et 29 October 2023
- Rail-Expo in Dreux les 24, 25 et 26 November 2023

Joël RASSCHAERT